



LIVING SPACES

ASSEMBLY INSTRUCTIONS

LUCA FULL PANEL BED

ITEM NO: Y2103W-333/334 SKU: 314657/314658

Y2103B-333/334 314569/314570

Y2103G-333/334 314613/314614

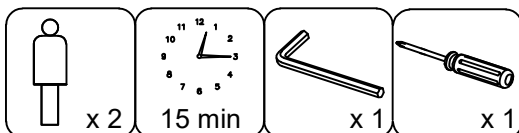
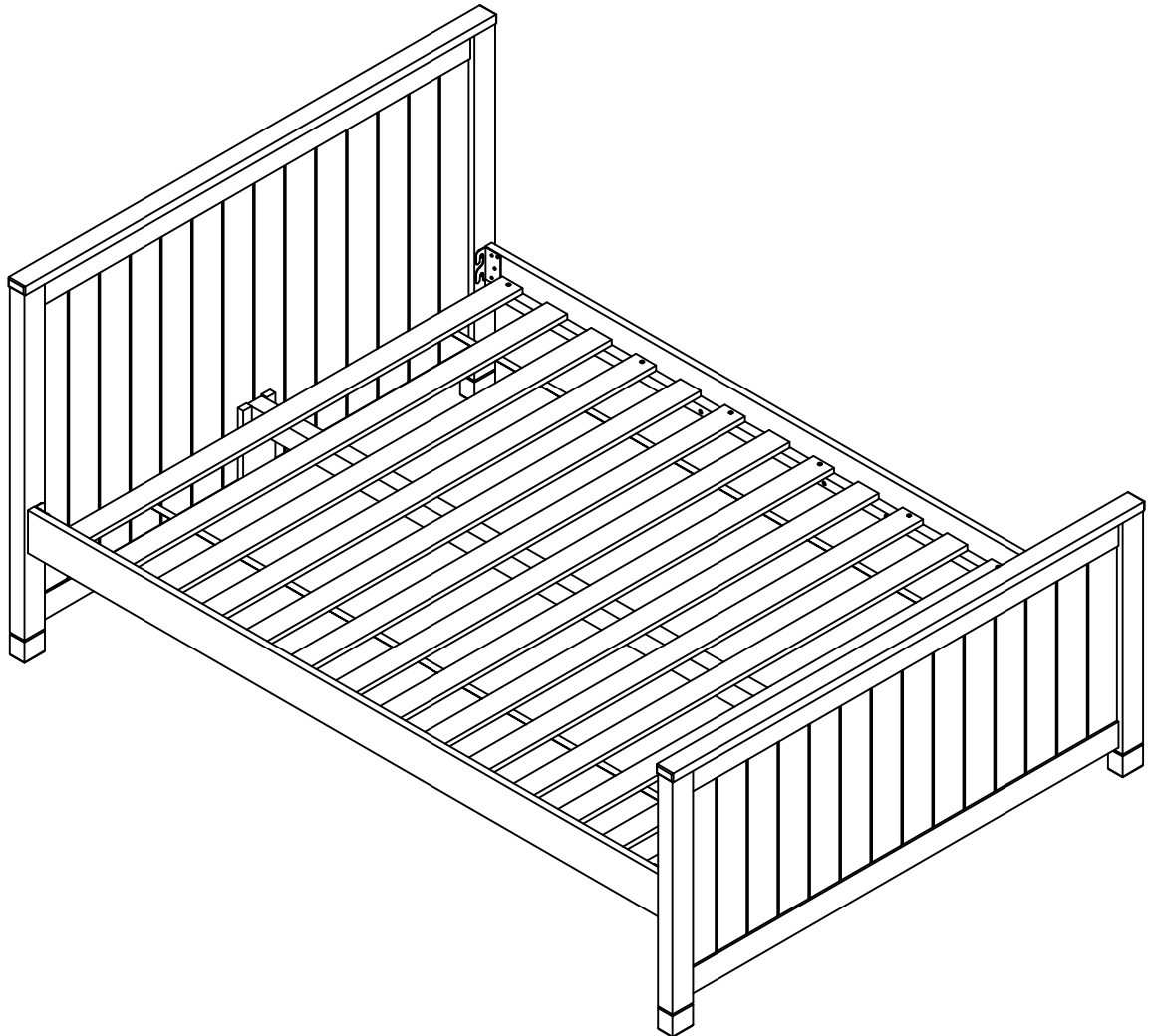

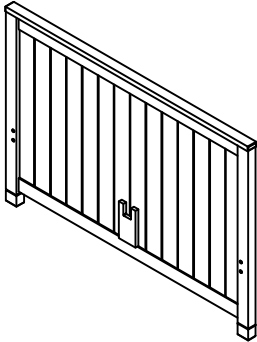
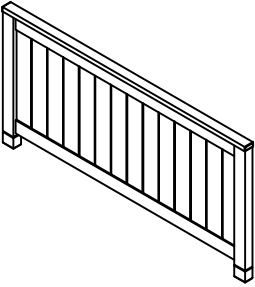
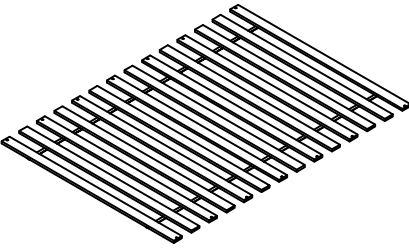

BOX 1- FL HEADBOARD/FOOTBOARD/SLATS PANEL BED

PART	SKU#	IMAGE	DESCRIPTION	QTY
<p align="center">Ⓐ</p>	<p>1994F-A-W: (White) 1994F-A-B: (Blue) 1994F-A-G: (Grey)</p>		<p align="center">Headboard</p>	<p align="center">1</p>
<p align="center">Ⓑ</p>	<p>1994F-B-W: (White) 1994F-B-B: (Blue) 1994F-B-G: (Grey)</p>		<p align="center">Footboard</p>	<p align="center">1</p>
<p align="center">Ⓔ</p>	<p align="center">1994F-E</p>		<p align="center">Slats</p>	<p align="center">1</p>

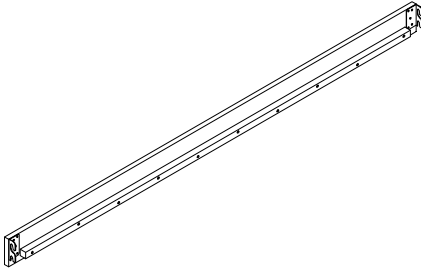
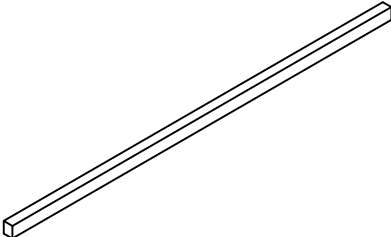
BOX 2- FL RAILS PANEL BED

PART	SKU#	IMAGE	DESCRIPTION	QTY
<p align="center">Ⓒ</p>	<p>1994F-C-W: (White) 1994F-C-B: (Blue) 1994F-C-G: (Grey)</p>		<p align="center">Rails</p>	<p align="center">2</p>
<p align="center">Ⓓ</p>	<p>1994F-D-W: (White) 1994F-D-B: (Blue) 1994F-D-G: (Grey)</p>		<p align="center">Slat support</p>	<p align="center">1</p>

Hardware List of Luca Full Panel Bed

Part	SKU#	IMAGE	DESCRIPTION	QTY
①	1994F-1(8)		Bolts M8*20mm	8
②	1994F-2(14)		Screws 8#*30mm	14
③	1994F-3(1)		Allen key 60*22*4mm	1

Note: Screwdriver will be prepared by yourself.

THE HARDWARE IS LOCATED IN THE PACKING ITEM

NOTE: MUST TIGHTEN SCREWS PERIODIACLLY. WITH USE SCREW MAY ENCOME LOOSE CHECK TIGHTNESS OF ALL SCREWS EVERY 6-8 WEEKS.

CLEANING INSTRUCTIONS:

After assembly, clean and polish the completed parts if necessary with soft cloth and industrial recognized furniture polish.

Detail view

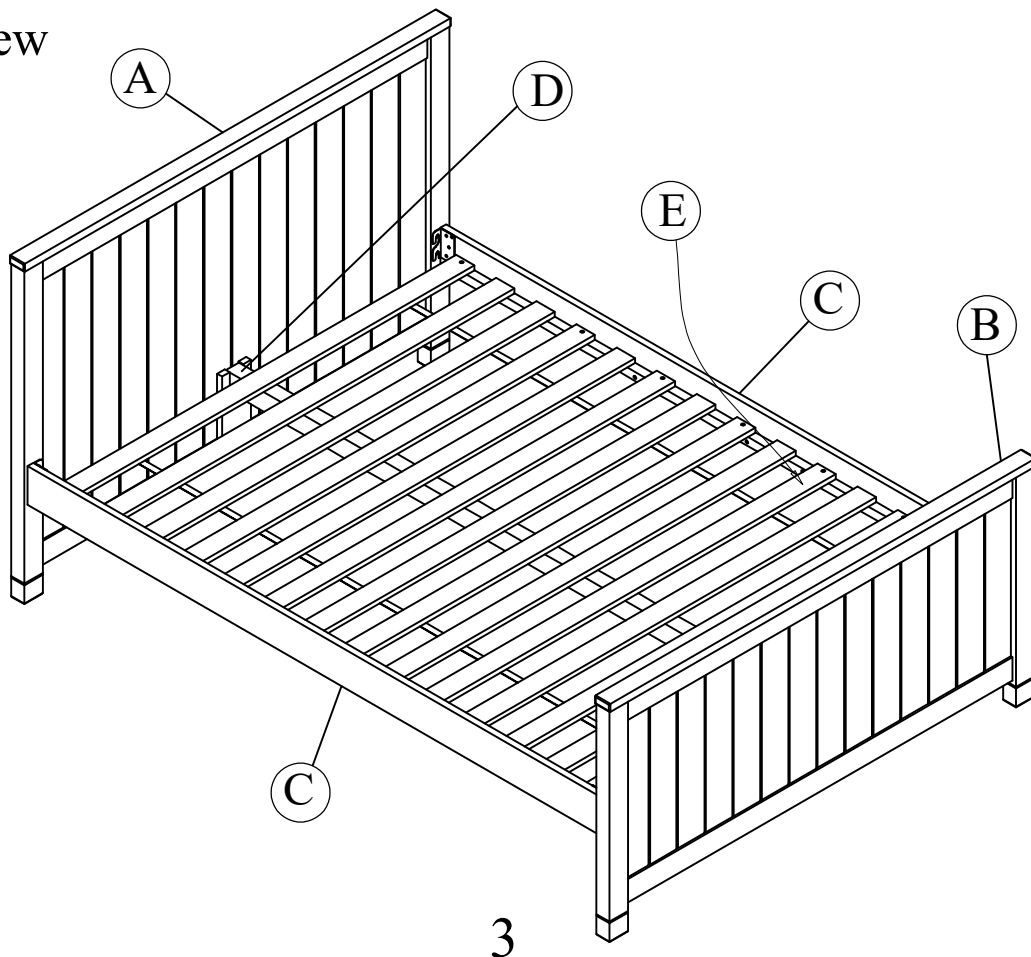

STEP 1:

- Attaching Bolt (1) to Pre-holes on Headboard (A), Footboard (B). Please be noted that "*should not tighten*" bolts.
 - Connecting the hook on Rail (C) to Bolt (1) and fasten again.
- ⚠ **Pay attention to rail orientation.**

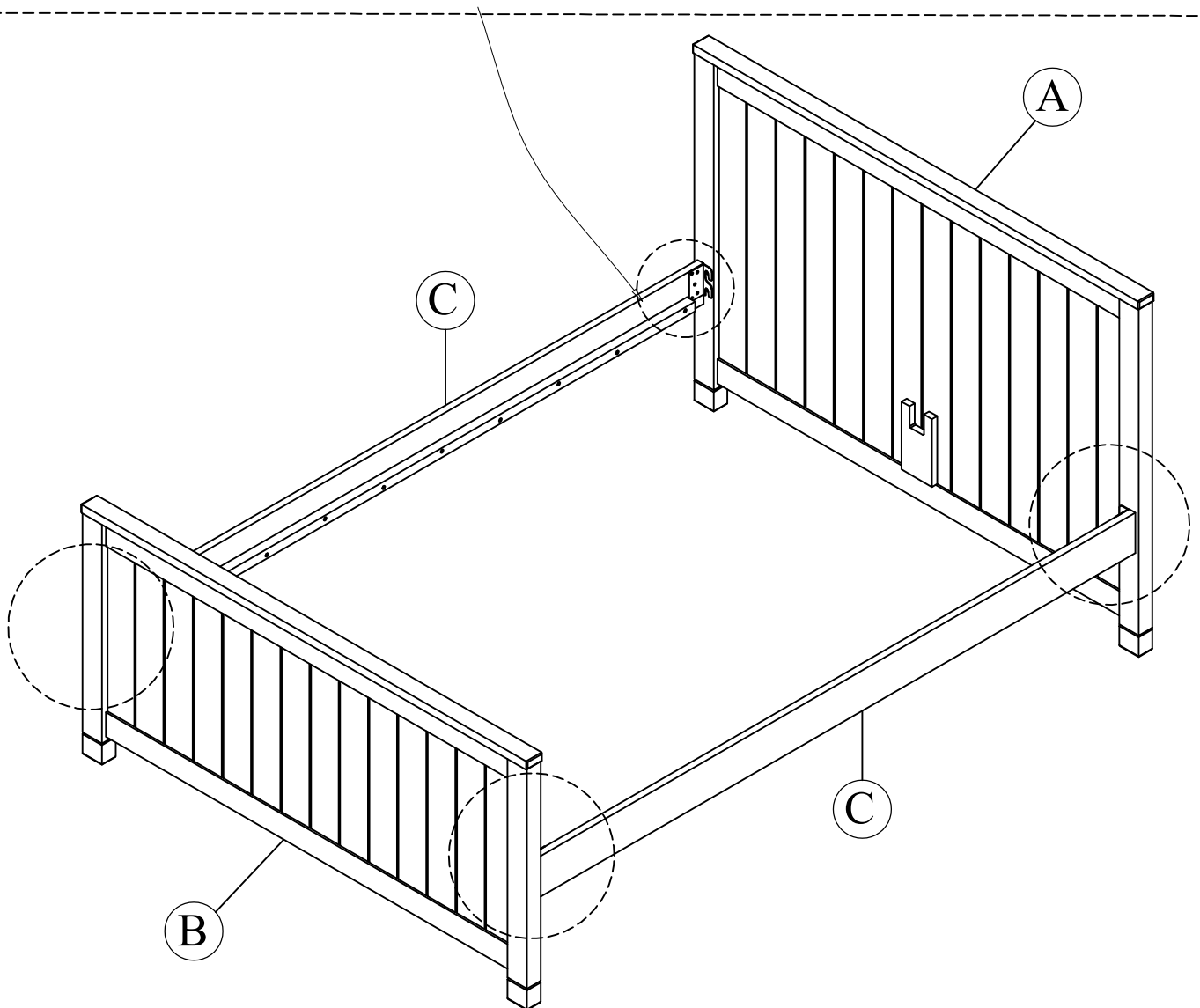
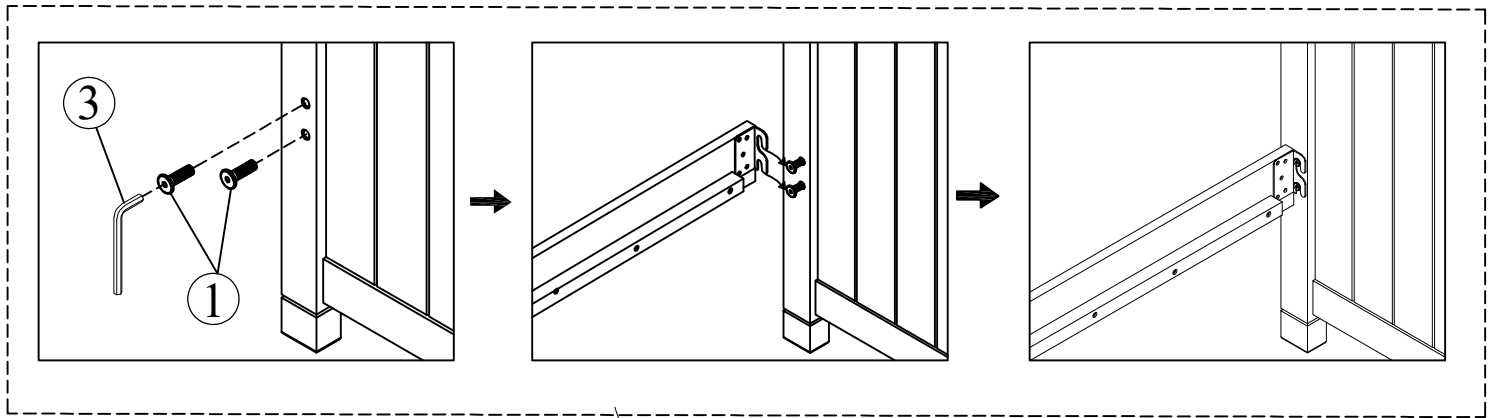

1=8 Pcs

STEP 2:

Place the Slat support (D) to Bed Frame

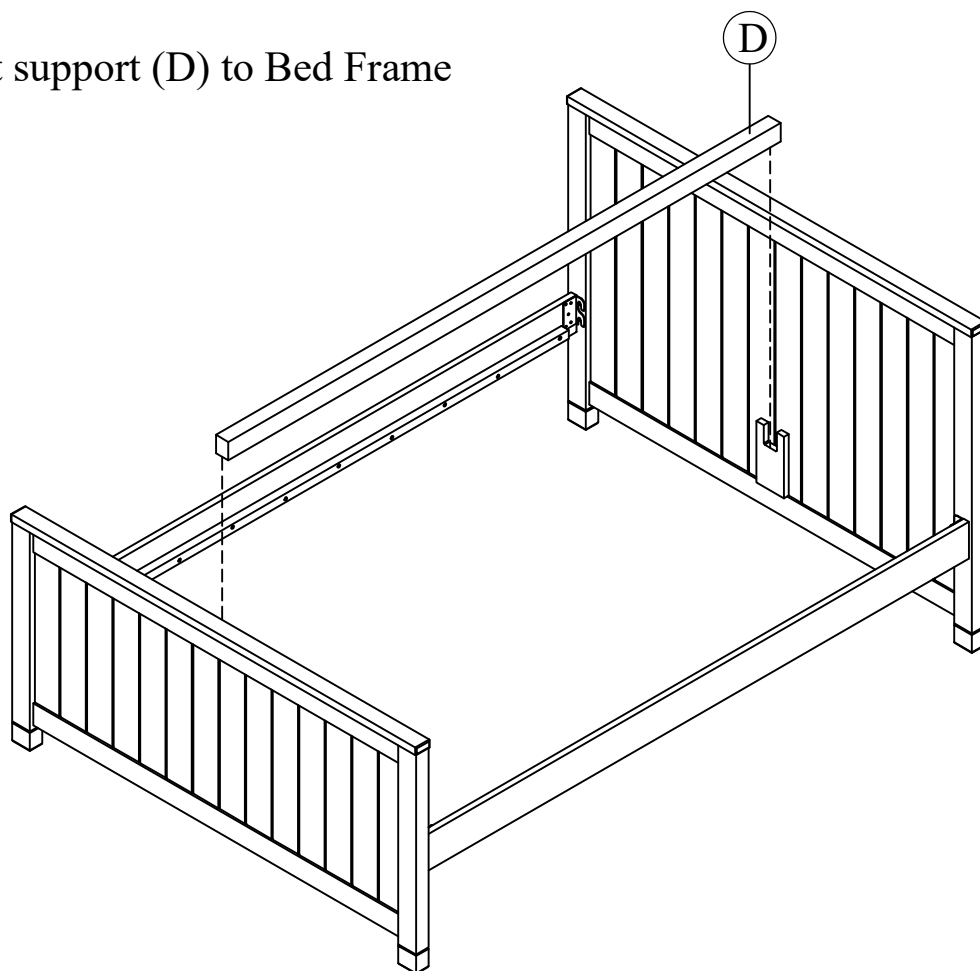

STEP 3:

Please fasten slats (E) by screw (2) into corresponding holes.

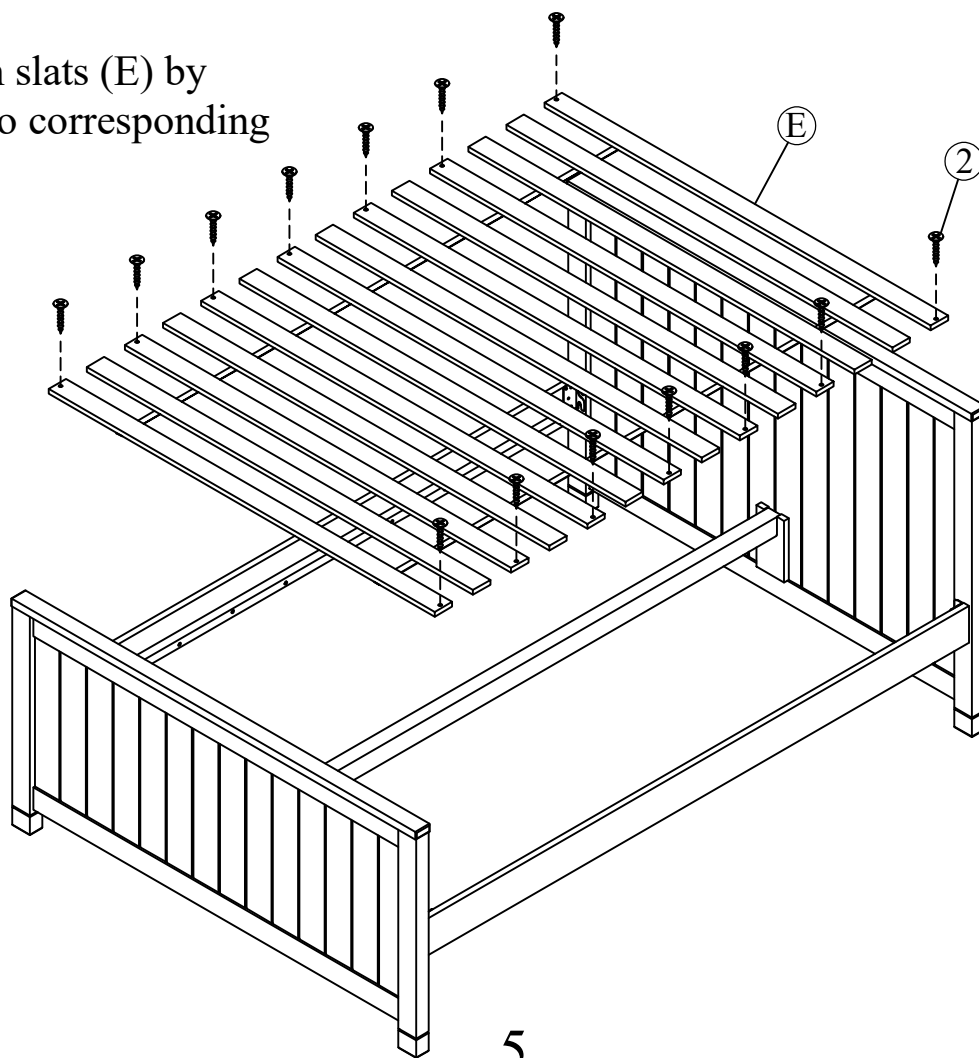

2=14 Pcs

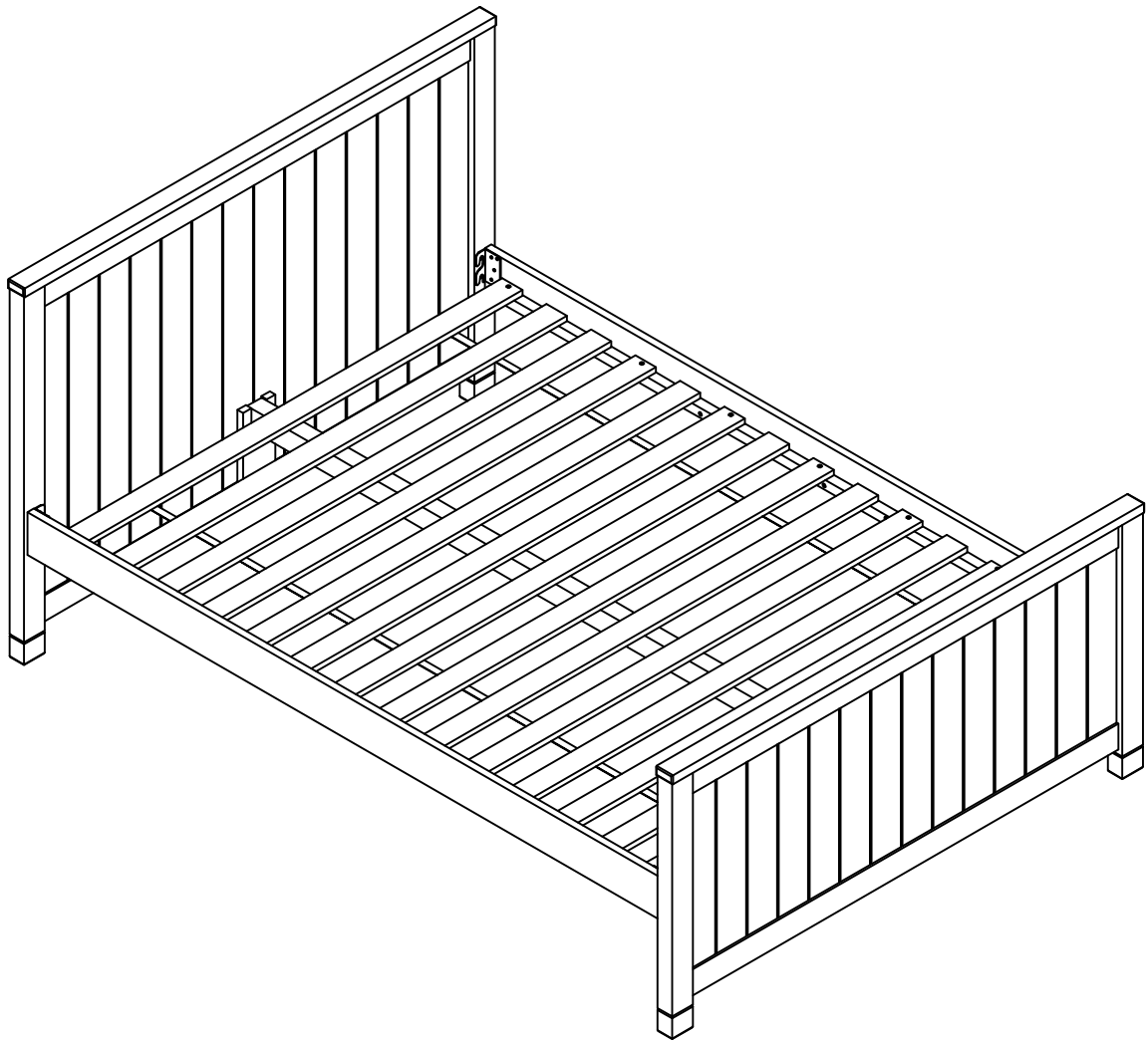

*That's it ! You've finished
assembling your item. Thank you!*



LIVING SPACES

ASSEMBLY INSTRUCTIONS

LUCA PANEL/BUNK/DAYBED TRUNDLE

ITEM NO: Y2103W-348

SKU: 314671

Y2103B-348

314583

Y2103G-348



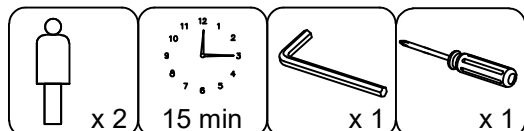
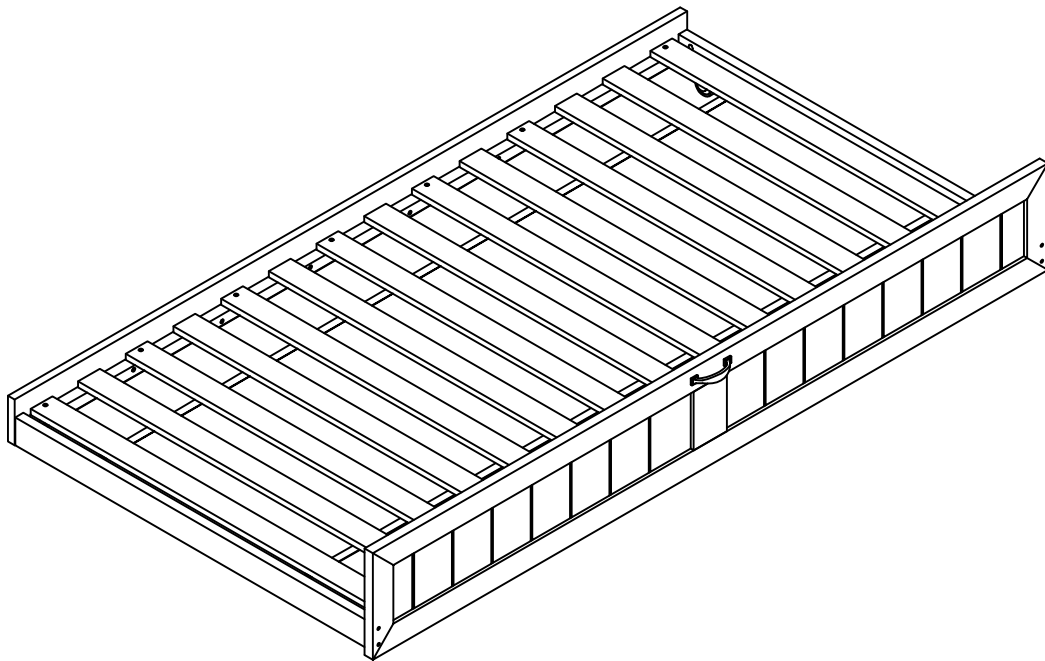

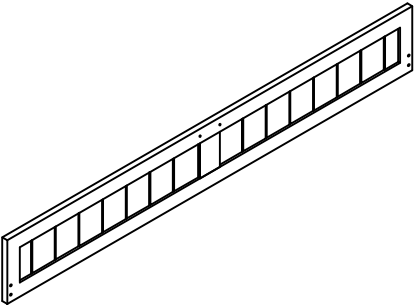
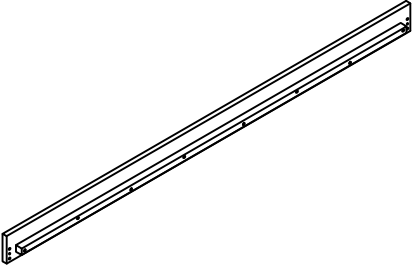
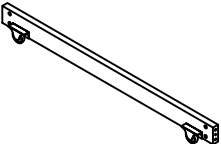
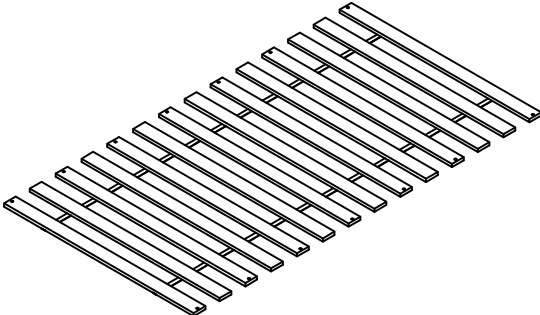

314627



Part list

PART	SKU#	IMAGE	DESCRIPTION	QTY
<p style="text-align: center;">(A)</p>	<p>1996-A-W: (White) 1996-A-B: (Blue) 1996-A-G: (Grey)</p>		<p style="text-align: center;">Front</p>	<p style="text-align: center;">1</p>
<p style="text-align: center;">(B)</p>	<p>1996-B-W: (White) 1996-B-B: (Blue) 1996-B-G: (Grey)</p>		<p style="text-align: center;">Back rail</p>	<p style="text-align: center;">1</p>
<p style="text-align: center;">(C)</p>	<p>1996-C-W: (White) 1996-C-B: (Blue) 1996-C-G: (Grey)</p>		<p style="text-align: center;">Side rails</p>	<p style="text-align: center;">2</p>
<p style="text-align: center;">(D)</p>	<p style="text-align: center;">1996-D</p>		<p style="text-align: center;">Slats</p>	<p style="text-align: center;">1</p>

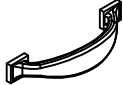
Hardware List of Luca Trundle

Part	SKU#	IMAGE	DESCRIPTION	QTY
①	1996-1(8)		Bolt and nut M8*70mm	8
②	1996-2(2)		Bolts M4*20mm	2
③	1996-3(4)		Dowel Ø8*40mm	4
④	1996-4(14)		Screws 8#*30mm	14
⑤	1996-5(1)		Handle	1
⑥	1996-6(1)		Allen key 60*22*4mm	1

Note: Screwdriver will be prepared by yourself.

THE HARDWARE IS LOCATED IN THE PACKING ITEM

NOTE: MUST TIGHTEN SCREWS PERIODIACLLY. WITH USE SCREW MAY ENCOME LOOSE CHECK TIGHTNESS OF ALL SCREWS EVERY 6-8 WEEKS.

CLEANING INSTRUCTIONS:

After assembly, clean and polish the completed parts if necessary with soft cloth and industrial recognized furniture polish.

Detail view

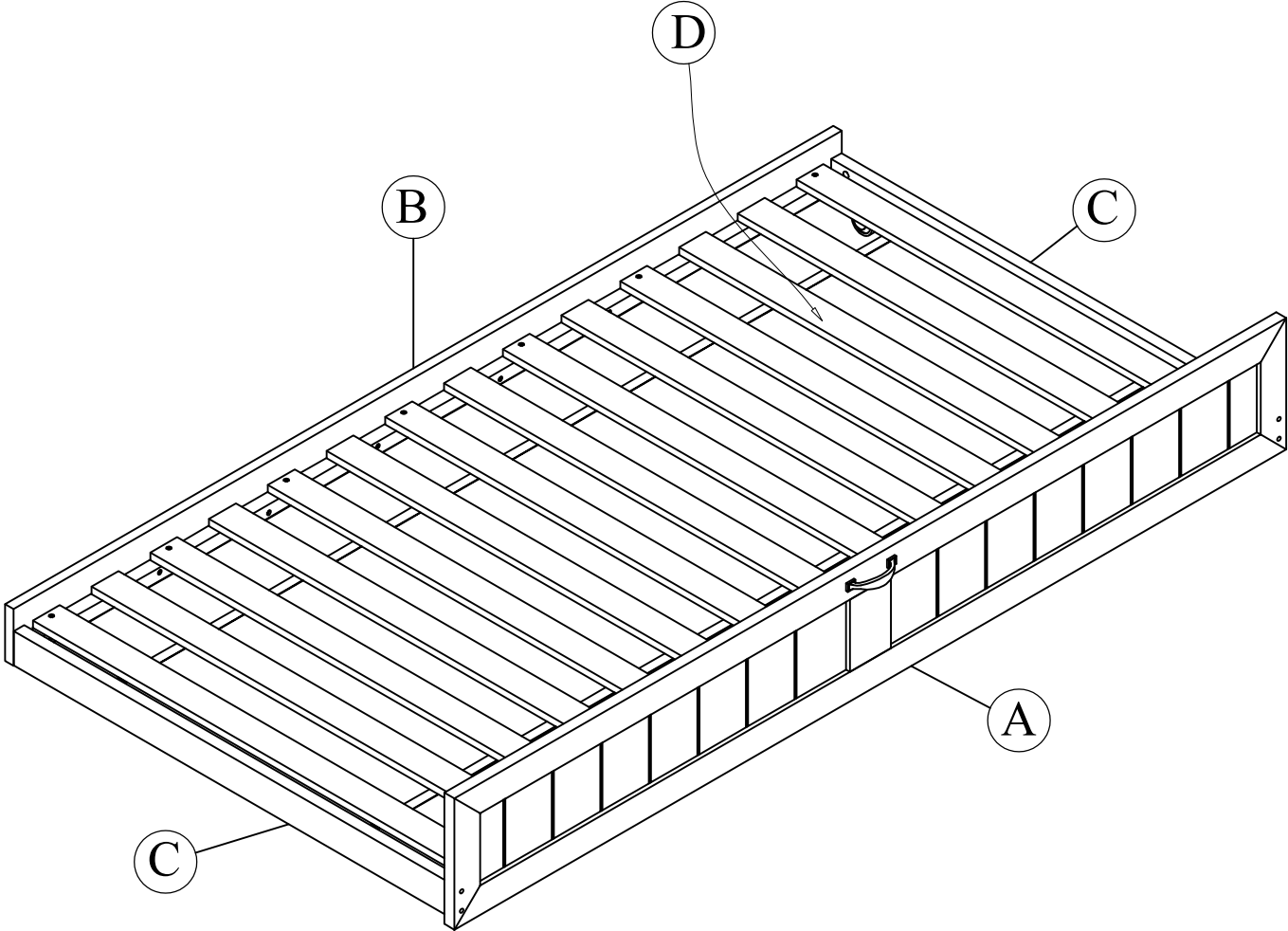

STEP 1:

- Firstly, please locate Side Rail (C) to Front (A), Back (B) by dowel (3).
- Fasten Side Rail (C) by (Bolt+nut) (1).

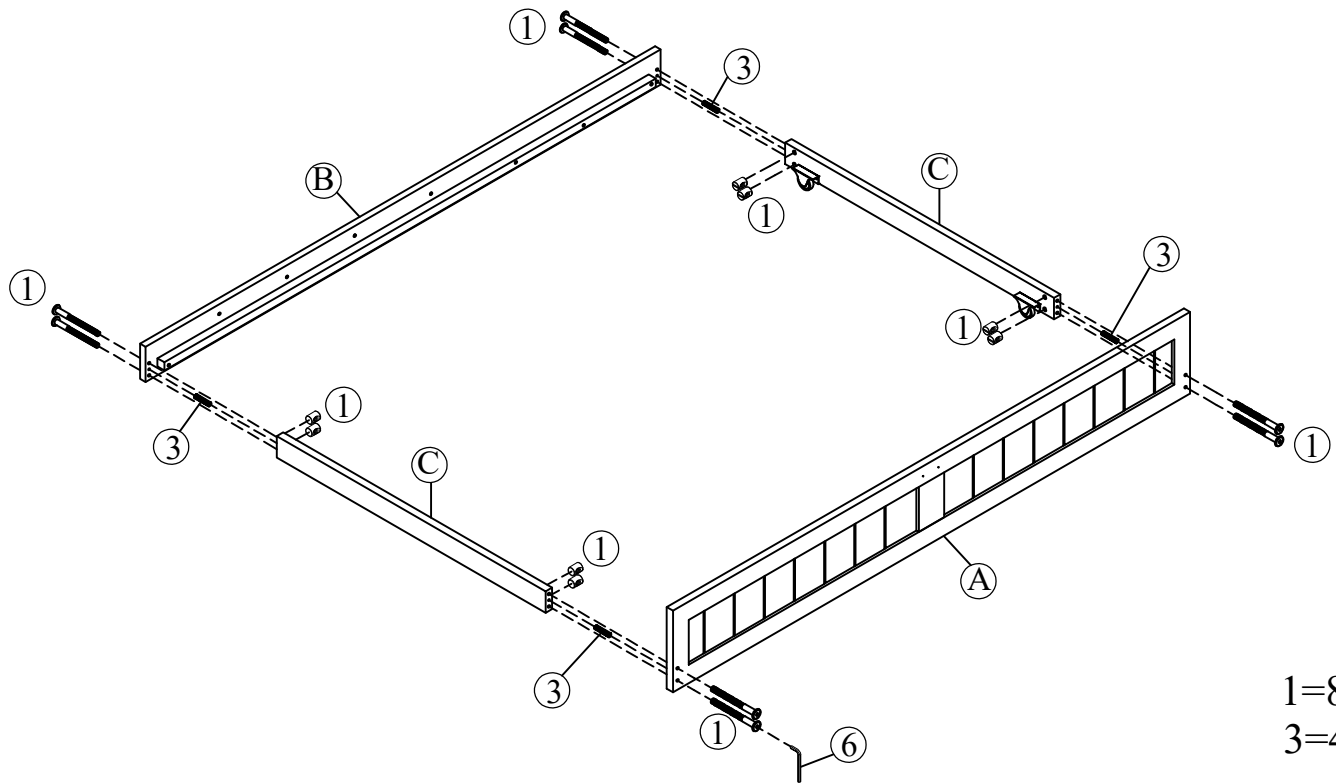
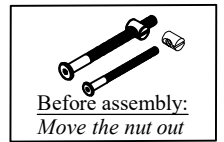

1=8 Pcs
3=4 Pcs

STEP 2: Please fasten slats (D) by screw (4) into corresponding holes.

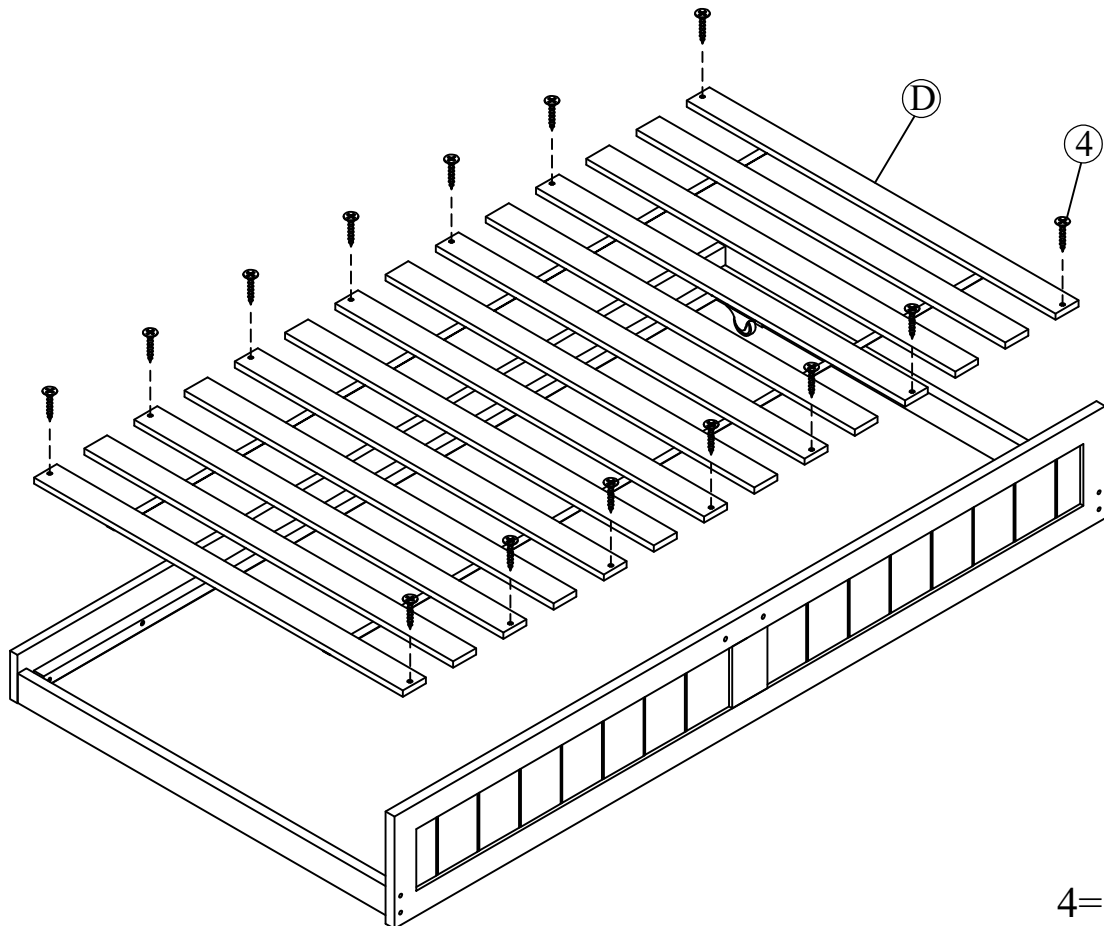

4=14 Pcs

STEP 3: Assemble the handle (5) into Front (A)

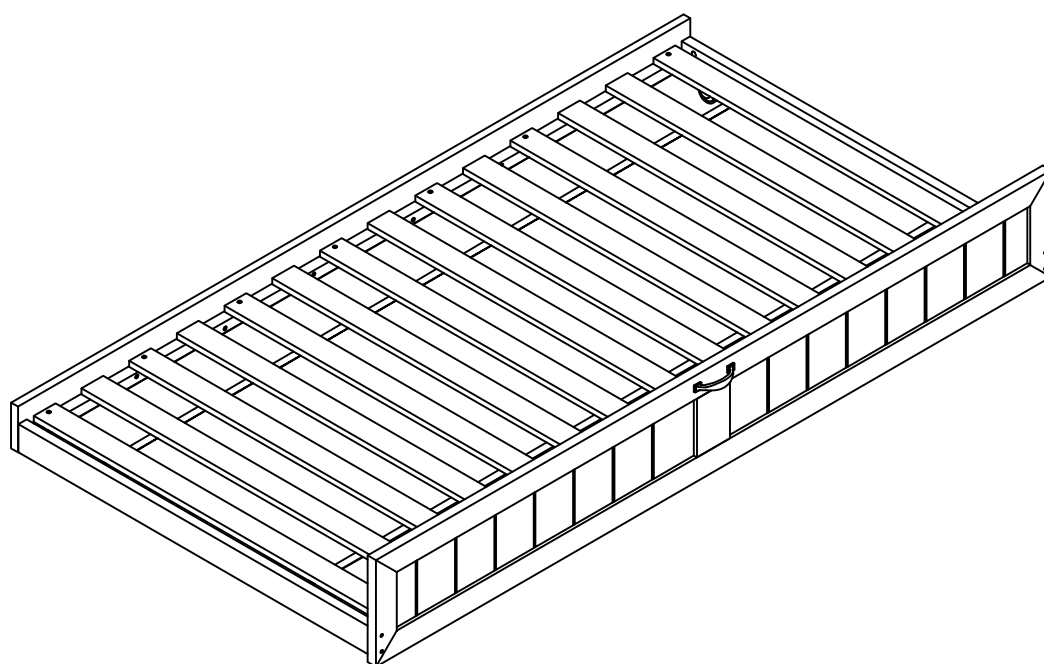
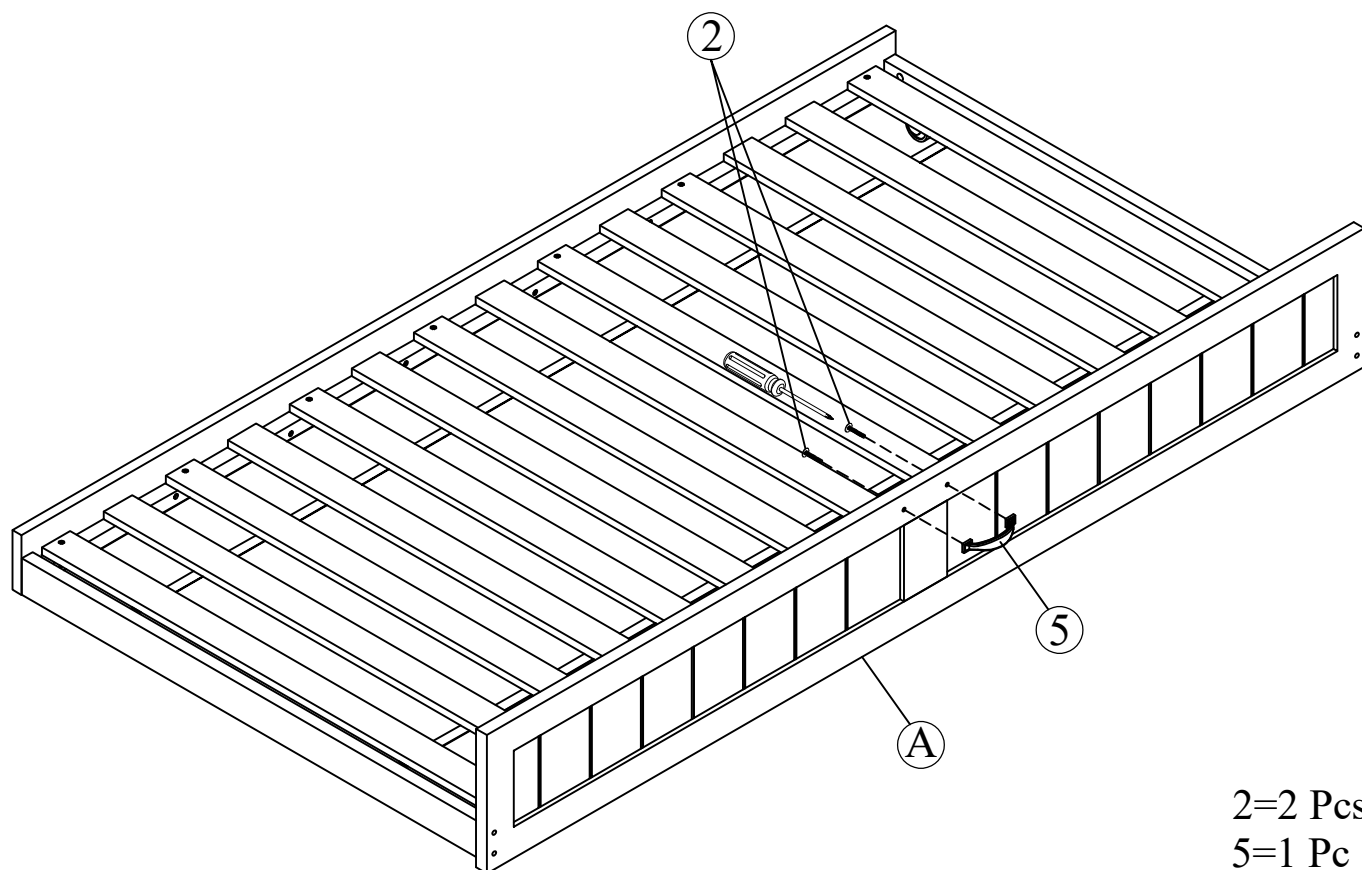

*That's it ! You've finished
assembling your item. Thank you!*